

# TXM Snake

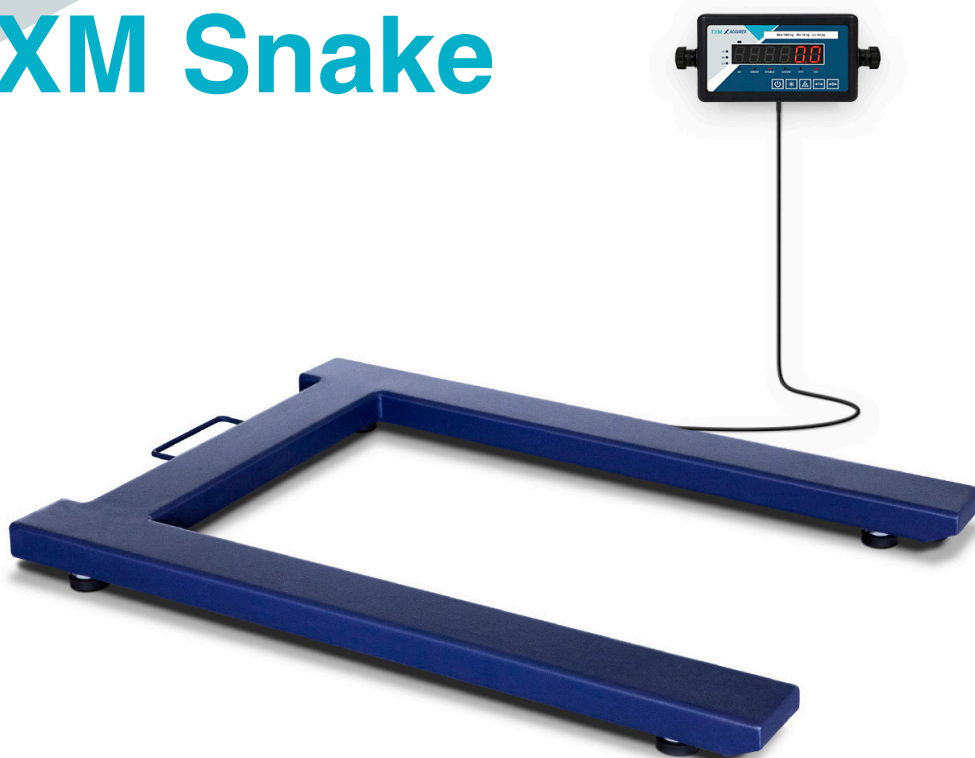

Industrial scale for pallets with CE-M verification for legal use

For weighing European pallets without ramps, can be easily moved to another location.

- Platform for weighing CE-M Verified European pallets with an autonomy of over 80 hours' use.
- 1500 kg capacity and 500 g resolution on-screen.
- With front wheels and a handle for easy transport; can weigh pallets without ramps.
- Highly resistant, U-shaped structure with epoxy treatment.
- Low height, only 90 mm, for easy access.
- Load sensors certified OIML R-60 class C in nickel-plated steel and IP65 protection.
- LED digit TXM display and 400 cm long cable.
- Weight counter with free sampling.
- Digital filter for weighing moving animals.
- Built-in Ni-MH battery.

The Accurex TXM Snake scale model is for legal use with **CE-M Verification** as standard. Manufactured with an epoxy treated steel structure; it includes a **TXM electronic display** and withstands robust, intensive treatment.

The **TXM display** is valid for **legal metrology**, with a 4 m cable, so it can be located away from the platform. Weighing response is extremely fast, in less than 2 seconds, and shows a stable, accurate weight.





## Operational functions

**European pallet weighing in any location,** with its handle and wheels allowing it to be moved easily.

**Can weigh moving animals.** Weighs animals on the platform via a digital filter that performs an average and shows the final weight once the calculation operations have been carried out.

**Piece counting.** Calculates the number of pieces from a sampling carried out in advance.

**Container taring** to display the net weight.

**Powered by a 220 V mains supply or its internal Ni-MH battery (included)** that is recharged via the same mains cable. The battery recharges when connected to the mains while the scale is being used.

**CE-M verified as standard.** The equipment is supplied duly calibrated and sealed, for use in applications where this certification is necessary.

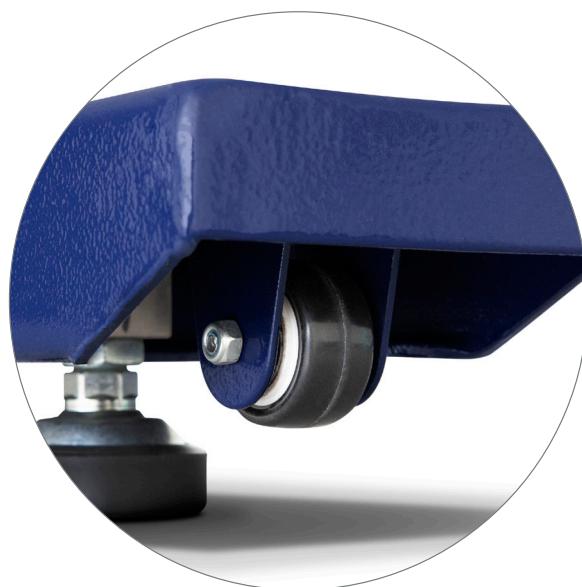

## Technical features

Model	TXM Snake 1.5T
Reference	72150
Capacity / max (kg)	1500 kg
Resolution / e (g)	500 g
Weighing units	g, kg
Maximum error (g)	± 0,1 %
Tare range (g)	- Max
Power	Mains 220 V, 50 Hz
Working temperature	-10°C / + 40°C
Structure	Steel with baked epoxy paint
Load sensors	4 x H8C Rebel IP65
Connections box	ABS sealed with IP65 protection
Structure thickness (mm)	5
Weighing platform dimensions (mm)	840 x 1210
Minimum height (mm)	90
Maximum height (mm)	105
Platform net weight (kg)	40
Packaging dim. (mm)	900 x 1270 x 80
Total weight with packaging <sup>1</sup> (kg)	50

## External dimensions (mm)

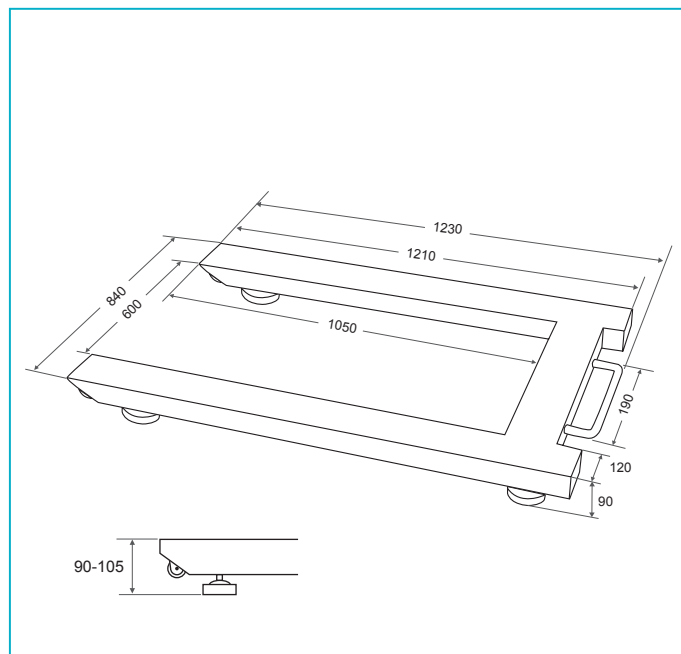

(1) Product packed in a single package.. The platform includes the display and accessories inside, accessible from the bottom.