



Advanced piece counting scale

- **Automatic piece count.**
- **Autonomous operation or with an auxiliary platform.**
- **Auxiliary floor or desktop platform of great capacity (bi-scale).**
- **Memory of 50 sample unit weights.**
- **Weight limit control with 2-level acoustic signal.**
- **Optional RS 232-C output for printers and labelling machines.**
- **Accumulation of weighing records.**
- **Removable and rechargeable internal battery.**



Precision counting with large capacity

Our VK makes counting and weight control (limits) tasks easier. We offer you a wide range of auxiliary platforms with capacities up to 3,000 kg, for counting very small pieces, with a resolution of up to 0.2 g.



Accurate counting with double platform

Performs high-precision sampling on the small pan and places the large parts container on the platform, for fast and convenient counting of large numbers of parts.

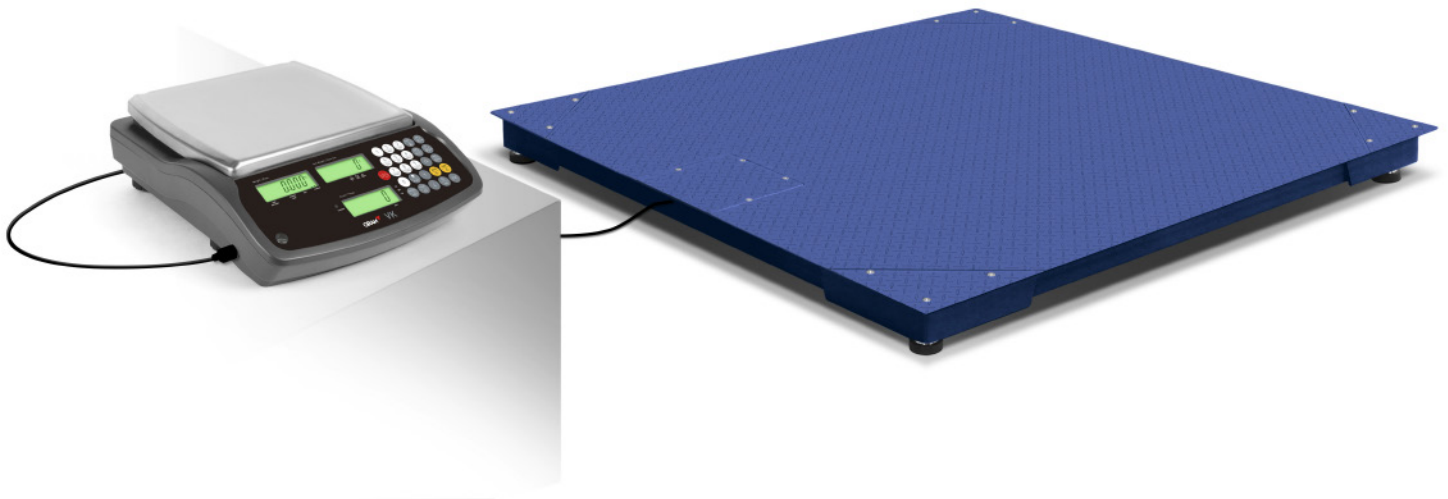

Counting of large quantities with precise sampling

Our Tortuga and Bengal floor platforms can count large quantities of pieces inside large containers.

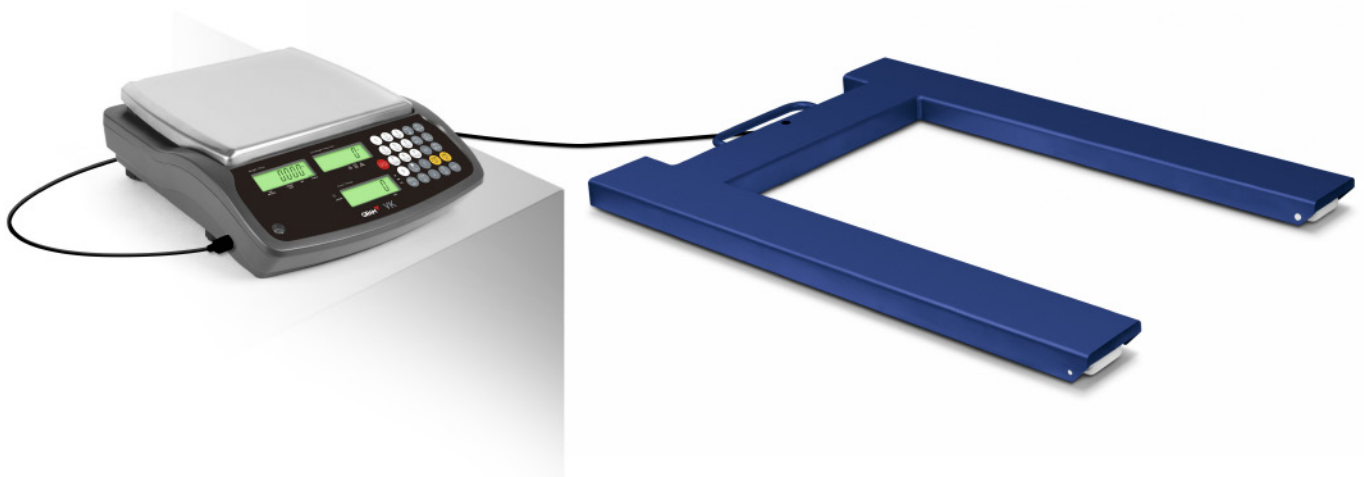

Portable equipment for counting large quantities

The Scorpion model calculates the number of pieces of a container on a EUR-pallet, which can be placed on the scale with a standard warehouse pallet truck.



Removable battery for easy replacement

Its battery is easily removable from the back of the equipment, for quick maintenance and without the need to open it.



Numeric keypad

Keypad to manually enter and store known unit weights (up to 50 items capacity).

Model	VK-6	VK-15	VK-30
Reference	72105	72106	72107
Capacity (g)	6,000	15,000	30,000
Resolution (g)	0.2	0.5	1
Power	220 V 50 Hz / battery 6V/4A		
Working temperature	0° / +40°C		
Battery life	48 hours with backlight off		
Viewing	3 backlit LCD displays		
Digit height (mm)	18mm		
Weighing units	g, kg, lb, pcs		
Structure material	ABS with AISI 304 stainless steel plate		
Connectivity	RS232C optional		
Sealing protection	IP54		
Weighing plate dimensions (mm)	309 x 252		
Product dimensions (mm)	382 x 344 x 124		
Product net weight (kg)	7.2		
Packaging dimensions (mm)	475 x 400 x 205		
Total weight with packaging (kg)	7.9		

External dimensions (mm)

VK

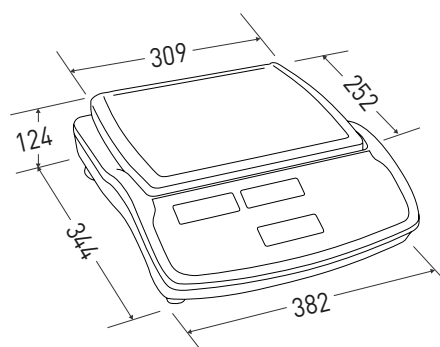



Model	VK-6 F1-60	VK-6 F2-60	VK-6 F2-150	VK-6 F3-150	VK-6 Tortuga SL-300	VK-6 Tortuga ML-600	VK-6 Tortuga GL-600	VK-6 Scorpion 1.5T
Reference	4639	4640	4641	4642	4643	4644	4645	4656
Capacity (kg)	60	60	150	150	300	600	600	1500
Resolution (g)	0.2							
Sample scale power supply	220 V 50 Hz / battery 6V/4A							
Sample scale battery life	48 hours with backlight off							
Working temperature	0° / +40°C							
Viewing	3 backlit LCD displays							
Digit height (mm)	18							
Weighing units	g, kg, lb, pcs							
Sample scale structure material	ABS with AISI 304 stainless steel plate							
Connectivity	RS232C optional							
Sample scale sealing protection	IP54							
Auxiliary scale sealing protection	IP65							
Sample weighing plate dimensions (mm)	309 x 252							
Auxiliary weighing plate dimensions (mm)	400 x 300	500 x 400	650 x 500	800 x 800	1000 x 800	1000 x 1000	920 x 1260	
Sample balance dimensions (mm)	382 x 344 x 124							
Auxiliary balance dimensions (mm)	400 x 300 x 102		500 x 400 x 122	650 x 500 x 145	800 x 800 x 105	1000 x 800 x 105	920 x 1290 x 84	
Height (mm)	102	122	145	105			84	
Sample balance net weight (kg)	7.2							
Auxiliary balance net weight (kg)	5.5	10.3	20.5	45	47	49	50	
Sample balance packaging dimensions (mm)	475 x 400 x 205							
Auxiliary balance packaging dimensions (mm)	490 x 390 x 130	590 x 490 x 150	760 x 610 x 180	810 x 810 x 260	1010 x 810 x 260	1010 x 1010 x 260	950 x 1300 x 92	
Total weight with sample balance packaging (kg)	7.9							
Total weight with auxiliary balance packaging (kg)	6.6	11.3	21.8	65	67	69	71	

Model	VK-6 Bengal 1210-600	VK-6 Bengal 1212-1.5T	VK-6 Bengal 1512-1.5T	VK-6 Bengal 1515-3T	VK-6 Penguin EP 1.5T	VK-6 Penguin 1212-1.5T	VK-6 Penguin 1515-1.5T
Reference	4646	4649	4651	4652	4653	4654	4655
Capacity (kg)	600	1500	1500	3000	1500	1500	1500
Resolution (g)	0.2						
Sample scale power supply	220 V 50 Hz / battery 6V/4A						
Sample scale battery life	48 hours with backlight off						
Working temperature	0° / +40°C						
Viewing	3 backlit LCD displays						
Digit height (mm)	18						
Weighing units	g, kg, lb, pcs						
Sample scale structure material	ABS with AISI 304 stainless steel plate						
Connectivity	RS232C optional						
Sample scale sealing protection	IP54						
Auxiliary scale sealing protection	IP65						
Sample weighing plate dimensions (mm)	309 x 252						
Auxiliary weighing plate dimensions (mm)	1200 x 1000	1200 x 1200	1500 x 1200	1500 x 1500	1600 x 900	1200 x 1200	1500 x 1500
Sample balance dimensions (mm)	382 x 344 x 124						
Auxiliary balance dimensions (mm)	1200 x 1000 x 106	1200 x 1200 x 106	1500 x 1200 x 106	1500 x 1500 x 106	2109 x 1120 x 108	1709 x 1429 x 108	2009 x 1720 x 108
Height (mm)	106				108		
Sample balance net weight (kg)	7.2						
Auxiliary balance net weight (kg)	73	84	103	122	165	159	221
Sample balance packaging dimensions (mm)	475 x 400 x 205						
Auxiliary balance packaging dimensions (mm)	1210 x 1010 x 150	1210 x 1210 x 150	1510 x 1210 x 150	1510 x 1510 x 150	1678 x 1140 x 372	1273 x 1435 x 372	1573 x 1725 x 372
Total weight with sample balance packaging (kg)	7.9						
Total weight with auxiliary balance packaging (kg)	85	99	121	144	180	176	248