



## Weigh where you need to

- Light cranescale.
- 21 mm red LED Display.
- Cast made of ABS.
  - Waterproof keyboard.
  - Remote control for distance control.
  - Auto-disconnection.

### Functions:

- Zero adjustment.
- Tare of receptacles.
- Weights accumulation.
- Piece counting.
- Hold function, last weight memory.

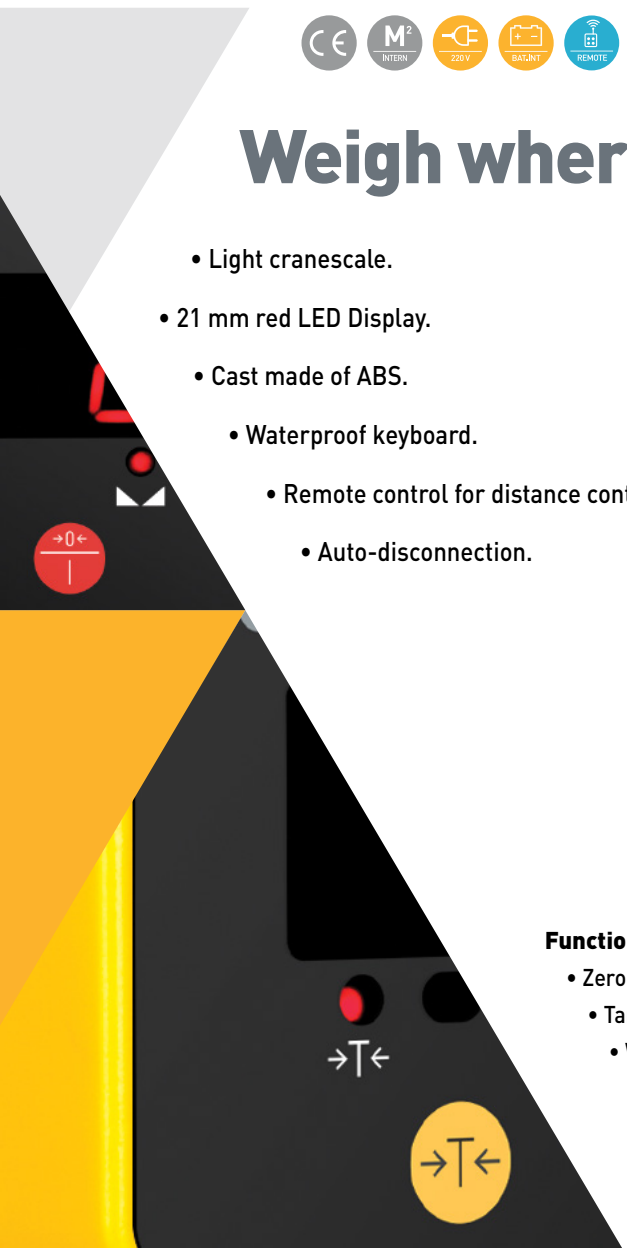
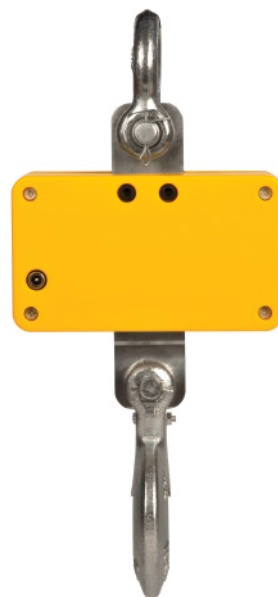



**Wireless remote control**

Control the system at distance, for more comfort.



Model	C3-300	C3-500	C3-1T
Reference	60203	60204	60959
Capacity	300 kg	500 kg	1.000 kg
Readability	50 g	100 g	200 g
Weight units	kg		
Tare range	100%		
Material structure	ABS		
Display	LED		
Digits size (mm)	21		
Power supply	DC 6V- Rechargeable battery 6V/1,3 Ah		
Battery duration	30 hours		
Working temperature	+0°C / +40°C		
Hook angle (mm)	35		
External dimension (mm)	330 x 230 x 325		
Total net weight (kg)	1,7	1,7	2,2
Packaging dimensions (mm)	330 x 120 x 230		
Total weight with packaging (kg)	2,1	2,2	2,7

**Dimensions (mm)**

C3

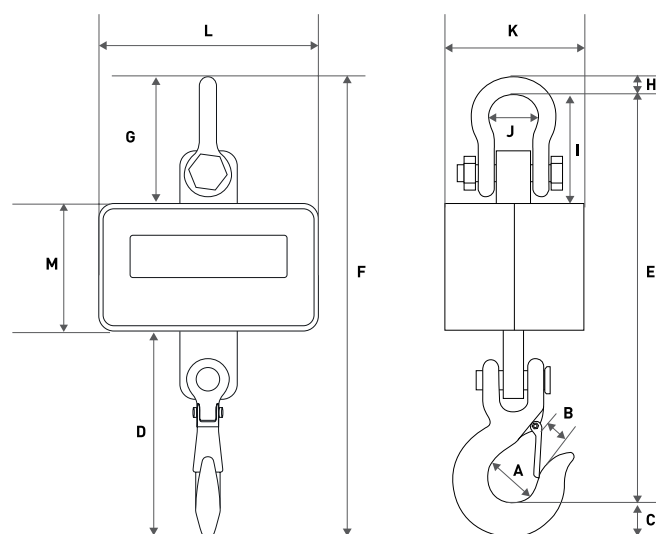

Ref.	Options
8024	ISOCAL certificate from 31 kg to 300 kg
8025	ISOCAL certificate from 301 kg to 600 kg
8029	ISOCAL certificate from 601 kg to 1500 kg

Model	A	B	C	D	E	F	G	H	I	J	K	L	M
C3-300 (mm)	35	25	30	150	275	320	90	13	39	33	70	145	85
C3-500 (mm)	35	25	30	150	275	320	90	13	39	33	70	145	85
C3-1T (mm)	35	25	30	150	275	320	90	13	39	33	70	145	85