

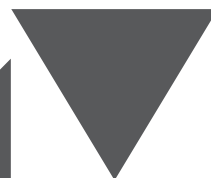

GRAM



SERIES

FM-S

120

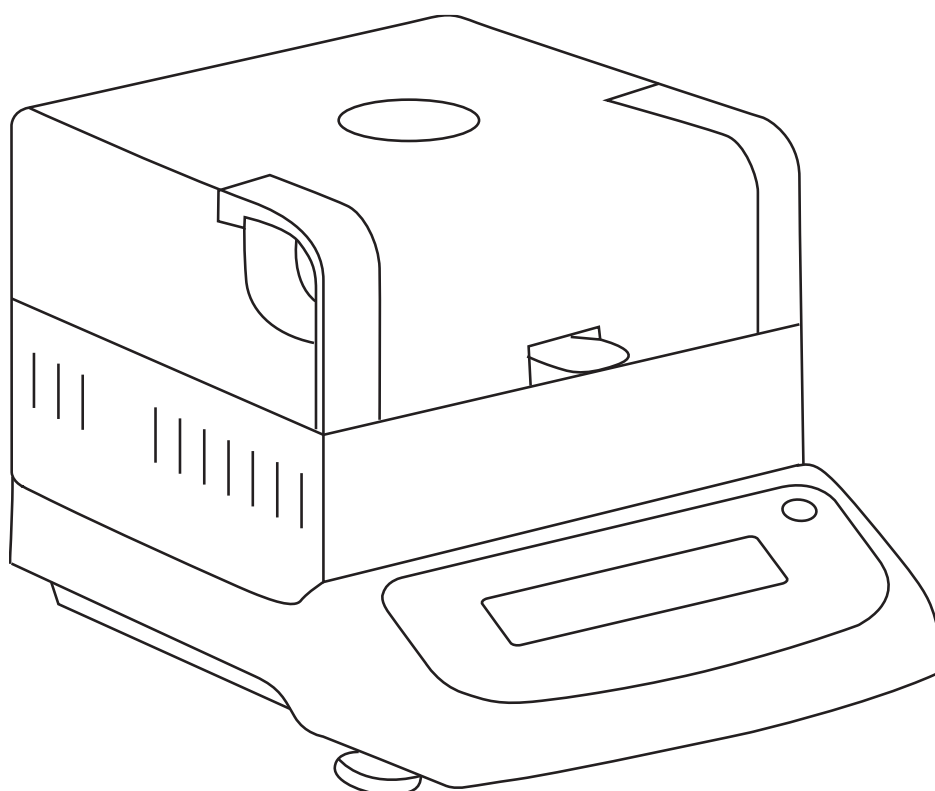

EN

USER MANUAL



1	Technical Data	3
1.1	Dimensional Sketch (mm)	4
2	Device overview	5
2.1	Keypad overview.....	6
2.2	Overview of display.....	8
3	Basic Information (General)	8
3.1	Intended use	8
3.2	Safety regulations.....	9
3.3	Warranty.....	10
3.4	Detection of Accessory Parts.....	11
4	Safety Precautions	11
4.1	Pay attention to the instructions in the Operation Manual	11
4.2	Personnel training	11
5	Transport and storage	11
5.1	Testing upon acceptance.....	11
5.2	Packaging / return transport	11
6	Unpacking, Setup and Commissioning	12
6.1	Installation Site, Location of Use.....	12
6.2	Unpacking, checking and installation.....	12
6.3	Leveling	13
6.4	Electric power supply.....	13
6.5	Initial Commissioning	14
6.6	Connection of peripheral devices	14
7	Menu	14
8	Calibration	16
8.1	Calibration with recommended calibration weight.....	17
9	Basic Operation	17
9.1	Zeroing.....	17
9.2	Sample weighing.....	18
9.3	Unit conversion.....	18
9.4	Weighing with tare.....	18
10	Settings	19
10.1	Temperature setting.....	19
10.2	Time setting.....	20
10.3	Shutdown mode setting.....	21
10.4	Weight loss rate setting.....	21
10.5	Step heating setting.....	21
10.6	How to save and check preset testing method.....	23
10.7	Printout.....	25
11	First Commissioning	25
12	Measurement	26
13	Test Optimization	27
13.1	How to get optimal testing results.....	27

13.2 Measuring Principle of Halogen Moisture Analyzer.....	27
13.3 Heating temperature.....	28
13.4 Heating time.....	28
13.5 Sample weight.....	28
13.6 Sample preparation.....	29
13.7 Sample type.....	29
14 Maintenance.....	30
14.1 Cleaning.....	30
14.2 Trouble-shooting.....	31
15 RS232C interface	32
15.1 Technical data.....	32
15.2 Interface.....	33
15.3 Printing mode.....	33

1 Technical Data

DAT FM Series Rapid Moisture Analyzer (External weight calibration)

Model		FM-120-S
Readability (d)		1mg
Capacity (max.)		120g
Maximum Allowable Error in Moisture Measurement (%)	Sample>2g	±0.05
	Sample>10g	±0.01
Operation Temperature Range (°C)		13-25
Recommended calibration weight not supplied (class)		100 g (E2)
Weighing pan size (mm)		Φ90
(Dimension L*W*H) (mm)		310*205*200
Warm-up time (minute)		20-30
Baud Rate Option		1200 2400 4800 9600
Display		LCD (liquid crystal display)
Heating Temperature Range (°C)		60-200
Heating mode		Normal heating, step heating, rapid heating
Shutdown mode		Auto shutdown, manual shutdown, timed shutdown
Time Setting		0~99 min.(1 min. at interval)
Input voltage		AC 110 -230 V, 50-60Hz
Interface		RS232C

1.1 Esquema dimensional (mm)



2 Device overview







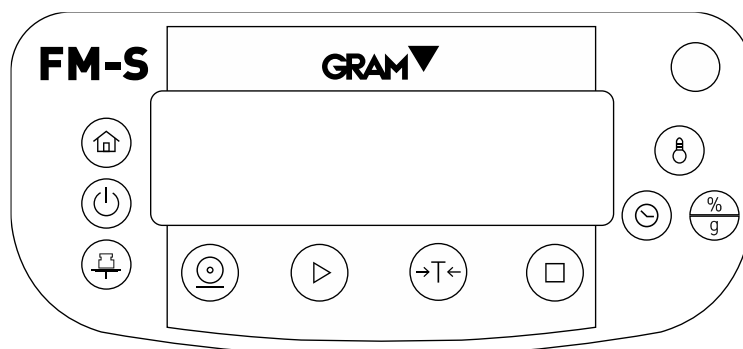

Position	Designation
1	Handle for opening and closing
2	Halogen lamp
3	Sample plate
4	Sample plate support
5	Level feet
6	Level bubble
7	Windproof plate

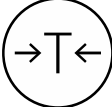
2.1 Keypad overview

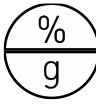
FM-120S KEYPAD

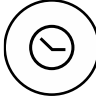

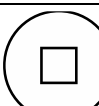
Key	Name	Function
	ON/OFF key	·Turn on/off
	TARE key	·Taring/Zeroing ·Increase setting value
	START key	·Start test ·Decrease setting value ·Confirmation
	PRINT key	·Print
	UNIT CONVERSION key	·Conversion between % and g
	MENU key	·Enter into menu
	TIME key	·Set heating time
	TEMPERATURE key	·Set heating temperature
	CAL key	·Calibration
	STOP key	·Stop test

2.2 Overview of display



No.	Display	Description
1	Max=888g	Maximum capacity of this moisture analyzer
2	d=8.8mg	Minimum readability of this moisture analyzer
3	88:88	Heating time
4	AUTO	Shutdown mode
5		Normal heating mode
6		Step heating mode
7		Rapid heating mode
8	Program: 88	Current heating procedure (heating method)
9	888°C	Setting temperature or current temperature
10		Humidity displays 5-segment trend
11	OK	Display of stable value
12	%DC	Percentage of solid content
13	%MC	Percentage of Moisture content
14	g	g as weighing unit

3 General Information (General)

3.1 Intended use

Thanks for purchasing our Rapid Moisture Analyzer.

The Halogen Moisture Analyzer you purchased is easy to operate, which helps to determine the moisture content of samples in a fast and reliable manner. Based on the principle of thermogravimetric analysis, it can be used to test moisture content of almost all substances. At the beginning of the measurement, the sample weight is measured by a halogen moisture analyzer. The sample is then rapidly heated by the integrated halogen heating unit to evaporate water. During the drying process, the instrument continuously measures sample weight and shows how it decreases. After the drying process is over, the moisture or solid content of the sample is displayed as the final result.

During the heating process, the heating speed of the sample and the uniform heating of its surface are of critical importance. For example, the halogen heating unit can reach the maximum heating capacity in a shorter time than the conventional infrared heating or oven method. It can also use high temperature as an additional factor to shorten the drying time. Uniform heating of the sample material ensures good repeatability of the drying results, and a smaller amount of sample is needed.

3.2 Safety regulations

For safe and reliable use of moisture analyzer, please observe the following preventive measures:



- This instrument is suitable for the determination of the moisture content of a sample. Any improper operation may result in personal danger or damage to the instrument.
- Please check if the input voltage and plug type marked on the label match the AC power source you use locally. This instrument comes with 3-pin and grounding plug. Do not disconnect the grounding plug.
- Make sure that the power cord does not cause any obstacle or risk of tripping.



- Do not operate the moisture analyzer in hazardous, humid, or unstable environments.
- Unplug the power supply when cleaning the moisture analyzer
- During the test, do not switch the input supply voltage and frequency (eg, do not switch between 110V and 220V).
- Make sure there is enough space around the moisture analyzer and at least 1 meter above.
- The moisture analyzer must only be operated by trained professionals who are familiar with the properties of the tested sample and the operation of the equipment.



- Use related safety equipment to operate moisture analyzers, such as safety glasses, gloves, protective clothing and respirator masks.
- Do not make any changes to the parts and other aspects of moisture analyzer. After-sales service should only be provided by factory authorized professionals.

Moisture Analyzer works in heating mode!



- Do not place any flammable materials above, below, or beside the moisture analyzer.
- Be careful when moving the testing sample when moisture analyzer is in use. Samples, heating elements, and the surroundings may be very hot, which can cause burns. Some samples require special care.
- For any sample substance that poses a safety hazard, please carefully analyze the possible dangerous consequences. We recommend that the moisture analyzer should be kept by a dedicated person.
- Fire/Explosion: Samples that contain flammable or explosive solvents may produce flammable or explosive gases or vapors when heated. When using such samples, work in a dry and low-temperature environment to avoid fire or explosion.
- Toxic/Combustible: Substances containing toxic or corrosive components can only be dried in a fume hood.
- Corrosion: Samples containing corrosive solvents evaporate upon heating and release corrosive gases at the same time. It is therefore advisable to take a small amount of material for testing.



- When removing or adding a small amount of items to be weighed in, do not operate the instrument with dynamic weighing. The "stability compensation" program installed in the instrument may cause an incorrect weighing value to be displayed! (for example: slowing draining liquid from the container on the instrument)
- Do not exceed the maximum weight of the instrument when weighing. This may damage the weighing system.
- Overloading exceeding the stated maximum load (max capacity) of a device must be strictly avoided. Please unload a possibly existing tare load, or this could possibly damage the instrument.
- Never operate balance in explosive environment. The balance is not explosion protected.
- The structure of the balance may not be modified. This may lead to incorrect weighing results, safety-related faults and destruction of the balance.

3.3 Warranty

Warranty claims shall be voided in case

- Our conditions in the operation manual are ignored
- The appliance is used outside the described uses
- The appliance is modified or opened
- Mechanical damage or damage by media, liquids, natural wear and tear
- The appliance is improperly set up or incorrectly electrically connected
- The measuring system is overloaded

3.4 Detection of Accessory Parts

In the framework of quality assurance the measuring-related properties of the balance and, if applicable, the testing weight, must be checked regularly. The responsible user must define a suitable interval as well as type and scope of this test.

4 Safety precautions

4.1 Pay attention to the instructions in the Operation Manual



Carefully read this operation manual before setup and commissioning, even if you are already familiar with this balance.

4.2 Personnel training

The appliance may only be operated and maintained by trained personnel.

5 Transport and Storage

5.1 Testing upon acceptance

When receiving the appliance, please check packaging immediately, and the appliance itself when unpacking for possible visible damage.

5.2 Packaging / return transport



- Keep all parts of the original packaging for a possibly required return.
- Only use original packaging for returning.
- Prior to dispatch disconnect all cables and remove loose/mobile parts.
- Pack display unit, weighing pan + accessories and power supply unit separately.
- Secure glass windshield against slipping (e.g. using an adhesive strip).
- Reattach possibly supplied transport securing devices.
- Secure all parts against shifting and damage as depicted



6 Unpacking, Setup and Commissioning

6.1 Installation Site, Location of Use

The balances are designed in a way that reliable weighing results are achieved in common conditions of use.

It will work accurately and fast, if you select the right location for your balance.

On the installation site observe the following:

- Place the balance on a firm, level surface;
- Avoid extreme heat as well as temperature fluctuation caused by installing next to a radiator or in the direct sunlight;
- Protect the balance against direct draught due to open windows and doors;
- Avoid jarring during weighing;
- Protect the balance against high humidity, vapors and dust;
- Do not expose the device to extreme dampness for longer periods of time. Non-permitted condensation (condensation of air humidity on the appliance) may occur if a cold appliance is taken to a considerably warmer environment. In this case, acclimatize the disconnected appliance for ca. 2 hours at room temperature.
- Avoid static charge of goods to be weighed or weighing container.

If electronic-magnetic fields or static charge occur, or if the power supply is unstable major deviations on the display (incorrect weighing results) are possible. In that case, the location must be changed.

6.2 Unpacking, checking and installation

Open packaging and remove all parts carefully.

Verify that there has been no damage and that all packing items are present.

Scope of delivery / serial accessories

1. Balance
2. Measuring tray
3. Weighing pan support
4. Draft ring
5. Measuring tray bracket
6. Country-specific mains plug
7. Bottom sheet (round)
8. Operating instructions



Prior to any installation and assembly works, the balance must be separated from the mains supply.

- Remove the transport securing from the lower side of the balance.
- Install the balance at the intended workplace.

The right place is decisive for the accuracy of the weighing results.

- Install the following parts in the right order

- Round bottom sheet
- Draft ring
- Weighing pan support
- Weighing pan

6.3 Leveling

Level balance with foot screws until the bubble level of the balance is in the prescribed circle.

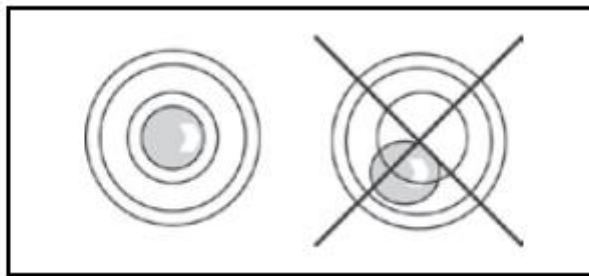

Attention: Check leveling regularly.

6.4 Electric power supply



Select a country-specific mains plug and plug it into the mains adapter.
Check, whether the voltage acceptance on the scales is set correctly.



Do not connect the scales to the power grid unless the information on the instrument (sticker) matches the local mains voltage.
Only use DAT original mains adapter. Using other makes requires consent by DAT.



Important:

- ✦ **Prior to commissioning check the mains cable for damage.**
- ✦ **Make sure that the mains adapter will not be damaged by liquids.**
- ✦ **The mains plug must be accessible at any time.**

Connect the mains adapter to the connecting socket on the backside of the balance and to the power mains.

The display unit lights up. As soon as the balance is supplied with energy, the indicator



is displayed.

6.5 Initial Commissioning

In order to obtain exact results with the electronic balances, your balance must have reached the operating temperature (see warming up time chapter). During this warming up time the balance must be connected to the power supply (mains, accumulator or battery).

The accuracy of the balance depends on the local acceleration of gravity.

6.6 Connection of peripheral devices

Before connecting or disconnecting of additional devices (printer, PC) to the data interface, always disconnect the balance from the power supply.

With your balance, only use accessories and peripheral devices by DAT, as they are ideally tuned to your balance.

7 Menu

You could set the moisture analyzer to suit your individual needs.

Navigation through Menu

- To access the Mainmenu (C1, C2, C3, C4, C5 and C6) : Pulse PRINT key
- In order to choose the Submenu parameters, use the keyboard TARE and START keys
- To confirm the value, press the STOP taste (when it is confirmed, the display shows the word „OK“ under the main menu).

Validation examples:

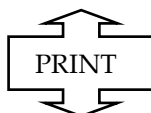
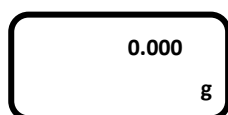
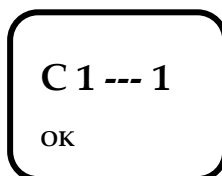

In weighing mode first press MENU key, then the PRINT key and the first menu item "C1" showing the current setting will be displayed.

C 1 --- 1



Press TARE key to select the individual items showing the current settings one by one.

C 2 --- 1



Press PRINT key to choose different settings.

C 3 --- 1



Press TARE key and START key to increase or decrease the setting values.

C 3 --- 2



C 3 --- 1

Press STOP key to confirm setting and "OK" is displayed at the lower left corner of the screen.

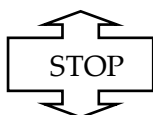

OK

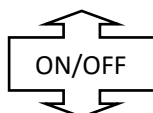

Press ON/OFF key and the screen displays "S-END". After 2 seconds, the device will store and update this setting and return to normal weighing state.

S--END

Note:

To ensure that the reset parameters could work properly, you need to press ON/OFF key twice to reboot the balance.

System Parameter Table

C X	C X-Y	MODE
C1: Calibration method	C1-0	Auto calibration (only applicable for internal calibration balances)
	C1-1***	External weights calibration**
C2: Shutdown mode	C2-0*	Manual shutdown
	C2-1*	Automatic shutdown*
	C2-2	Timed shutdown
C3: Program testing method	C3-0	Testing method 1**
	C3-1	Testing method 2

	C3-99	Testing method 100
C4: Baud rate	C4-0	2400
	C4-1	4800
	C4-2	9600*
C5: Weight loss rate	C5-0	1mg/10s applicable for quick determination with defined trend
	C5-1	0.1mg/20s applicable for rapid drying
	C5-2	0.1mg/50s applicable for most samples*
	C5-3	0.1mg/90s applicable for medium dry samples
	C5-4	0.1mg/120s applicable for slow drying samples with low moisture content (plastic, etc)
C6: Heating method	C6-0	Standard heating **
	C6-1	Warming step by step (Only Timer)
	C6-2	Rapid heating

* **Option forbidden**

** **Factory settings**

*** **The FM120S configuration has to be done with C1-1, because it doesn't contain an intern calibration system**

8 Calibration

As the acceleration value due to gravity is not the same at every location on earth, each balance must be coordinated - in compliance with the underlying physical weighing principle - to the existing acceleration due to gravity at its place of location (only if the balance has not yet been calibrated to the local gravity).

This adjustment process must be carried out for the first commissioning, after each change of location as well as in case of fluctuating environment temperature.

To receive accurate measuring values it is also recommended to adjust the balance periodically in weighing operation.

Observe stable environmental conditions. A warming up time is required for stabilization.

Ensure that there are no objects on the weighing pan.

Attention:

- Carry out calibration as near as possible to the balance's maximum weight.
- Observe stable environmental conditions. Stabilization requires a certain warm-up time.
- Ensure that there are no objects on the weighing pan.

8.1 Calibration with recommended adjustment weight

We recommend to carry out all calibrations as close as possible to the maximum load of the balance.

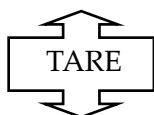
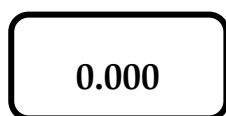

Press the TARE button 3 seconds, « CAL 100 » will appear on the display.



Place 100g standard weight on the weighing pan.



Press TARE key again.



After around 3 to 5 seconds, the screen will display -----

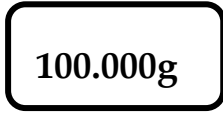

Afterwards, the screen displays 100.000g. The calibration is over.

The device returns to normal weighing mode after successful calibration.

9 Basic Operation

9.1 Zeroing

In order to obtain optimal weighing results, reset the balance to zero before weighing.



Unload the balance and press TARE key

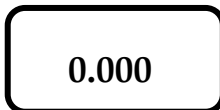

Wait until the balance displays 0.000

9.2 Sample weighing



Press TARE key to zero the balance.

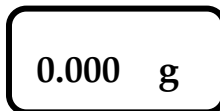

Place the sample to be weighed on the sample plate and close the windshield.

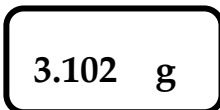

Wait for stable display ("OK" is displayed at the lower left corner of the screen) and read weighing result.

Overload warning:

Overloading exceeding the stated maximum load (max capacity) of a device must be strictly avoided. Please unload a possibly existing tare load, or this could possibly damage the instrument.

Exceeding the maximum load is indicated by the display "E " or "H". Unload weighing system or reduce preload.

9.3 Unit conversion

By repeatedly pressing the “%/g” key, the weighing value could be switched over to the available weighing and application units.



9.4 Weighing with tare

The dead weight of any weighing container may be tared away by pressing the TARE key, so that the following procedures show the net weight of the goods to be weighed.

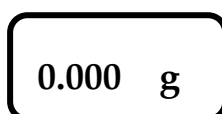

Set the balance to zero

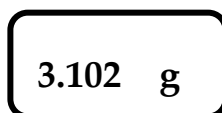

Place an empty weighing container on the sample plate, and the weighing result is displayed.

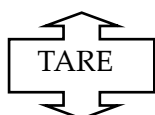

Wait for stable display and press TARE key

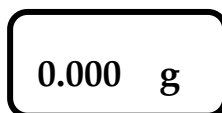

The screen shows 0.000

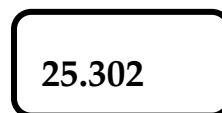

Weigh the material. The net weight will be shown.

Note:

- When the balance is unloaded, the saved taring weight will be displayed with a negative sign.
- To delete the stored tare value, remove the load from sample plate and press TARE key.

10 Settings

10.1 Temperature setting

TEMPERATURE

Press TEMPERATURE key and the screen displays the current temperature

01

TARE

Press TARE key each time, and the displayed temperature increases by 1°C

02

START

Press START key each time, and the displayed temperature decreases by 1°C

01

Press TEMPERATURE key to confirm the setting value and return to normal weighing mode.

TEMPERATURE

10.2 Time setting (1 ~99 minutes)

Regardless of the heating mode and shutdown mode, the heating time is displayed during the heating process and the total heating time is shown after the heating process is over. The screen displays the preset heating time on stand-by mode.

TIME

Press TIME key and this sign  on the screen flickers and displays the preset time in minutes

05

TARE

Press TARE key each time, and the displayed time increases by 1 minute

06

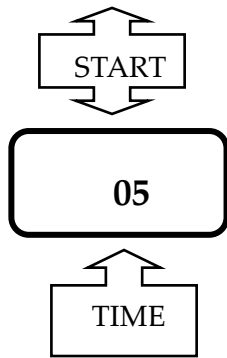

Press START key each time, and the displayed time decreases by 1 minute

Press TIME key to confirm the setting value and return to normal weighing mode.

10.3 Shutdown mode setting

The shutdown mode is used to determine the threshold point of the moisture analyzer to stop testing and display results.

A. Timed shutdown mode: please refer to **Chapter 10.2**.

The device automatically stops testing according to the preset time and displays the percentage of moisture content of the testing sample.

B. Auto-shutdown mode: please refer to **Chapter 7** and set the balance to C2---1. The "AUTO" display on the screen indicates the auto-shutdown mode.

The device automatically stops testing according to the preset weight loss rate and displays the percentage of moisture content of the testing sample.

10.4 Weight loss rate setting

C5---0 (0.1mg/10s)	applicable for quick determination with defined trend
C5---1 (0.1mg/20s)	applicable for rapid drying
C5---2 (0.1mg/50s)	applicable for most samples, standard setting
C5---3 (0.1mg/90s)	applicable for medium dry samples
C5---4 (0.1mg/120s)	applicable for slow drying samples with low moisture content

Please refer to **Chapter 7** and choose corresponding setting from C5---0 to C5---4.

10.5 Step heating setting (including 4 phases)

A. Automatic heating mode (C2---1 mode)

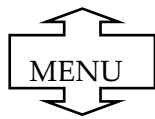
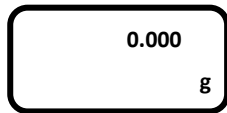

In weighing mode first press MENU key, then press PRINT key and the first menu item "C1---0" showing the current setting will be displayed.

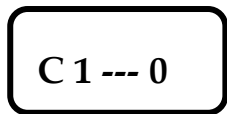
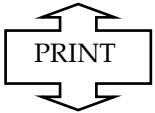

Press TARE key to select the individual items showing the current settings one by one

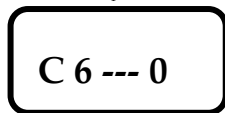
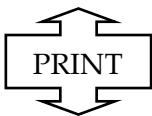
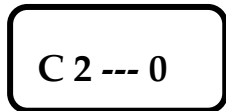

Press PRINT key to choose different settings until the screen displays C6

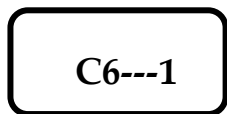
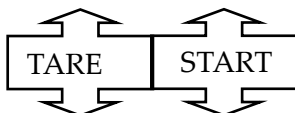

Press TARE key and START key to increase or decrease the setting values until the screen shows C6---1 (see Chapter 7)



Press TIME key and the screen displays STEP 1

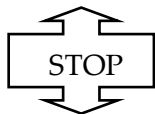

Press STOP key and the screen displays the current setting

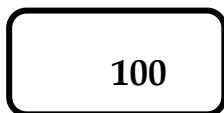

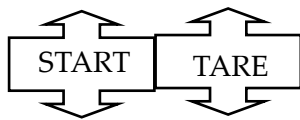

temperature, such as 100°C



Press TARE key and START key to increase or decrease the temperature until the screen shows your desired value, for instance, 80°C



Press STOP key to save this setting.



Press PRINT key and the screen displays STEP 2

.....

Please refer to the above procedures to set the temperature for STEP 2 , STEP 3 and STEP 4

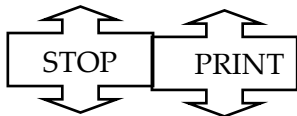

Press STOP and PRINT key and the screen displays S-END

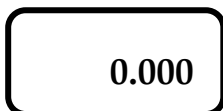

Press ON/OFF key twice, the device will store and update this setting.

Note:

The lowest temperature should be set to 40°C on Step 4.

B. Timed heating mode (C2---2 mode)

The operations are compatible to automatic heating mode.

Note:

If only 3 steps are required, the time should be set to 0 on Step 4.

10.6 How to save and check preset testing method

A. Save the preset testing method

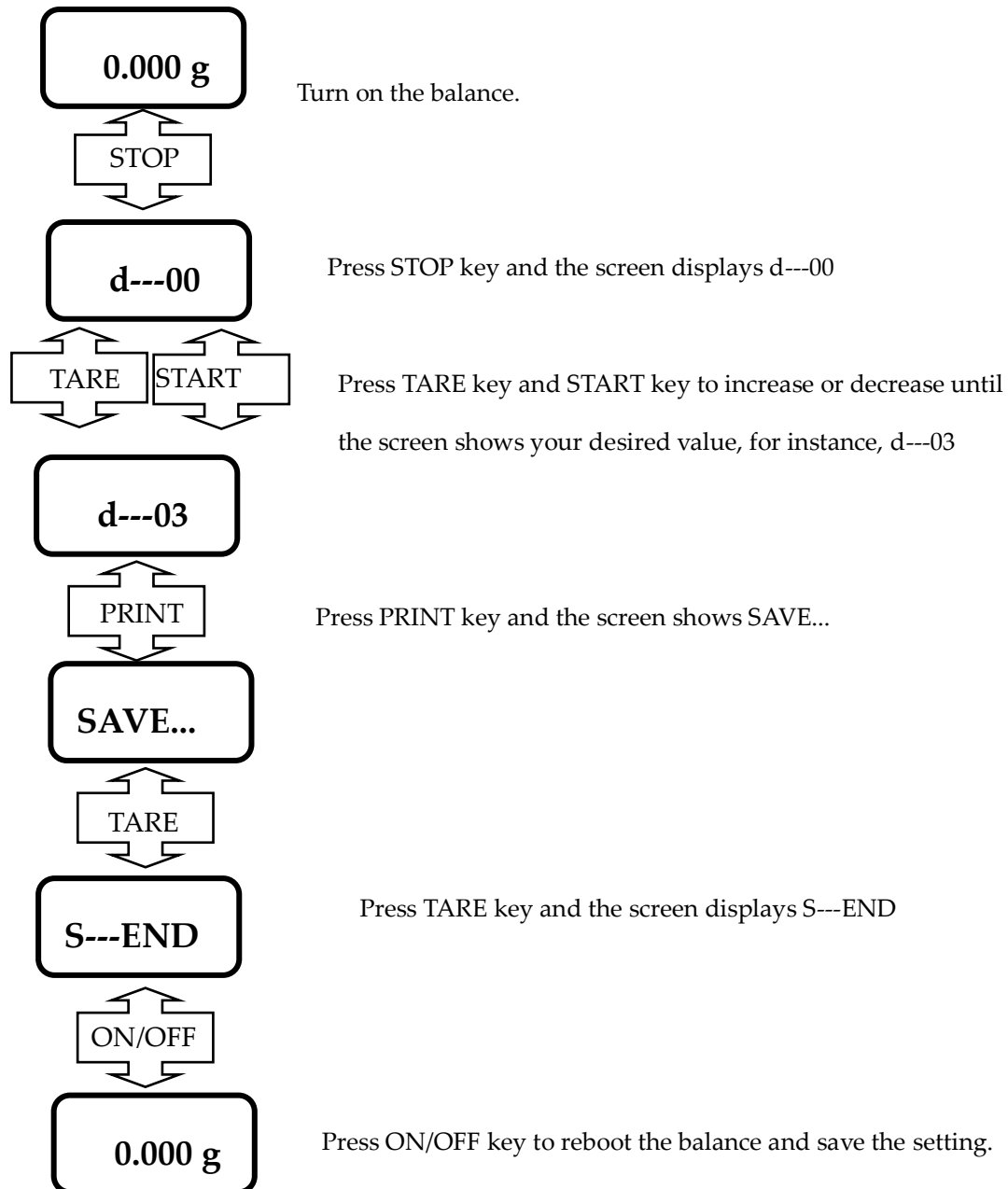

B. Check the preset testing method (0~99 testing methods)

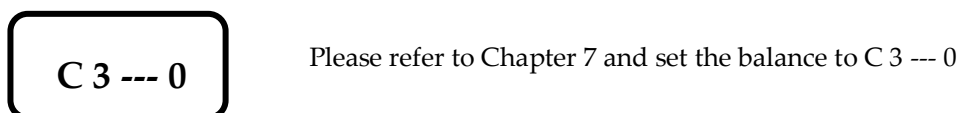

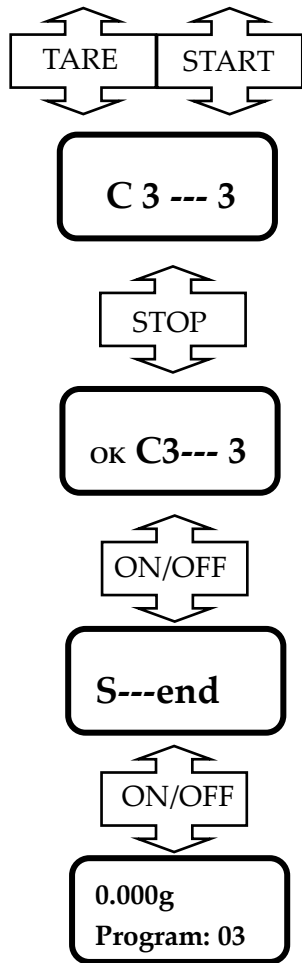

Press TARE key and START key to increase or decrease until the screen shows your desired value, for instance, C 3 --- 3

Press STOP key and the screen will display OK sign at the lower left corner to select the current mode.

Press ON/OFF key to save this setting

Press ON/OFF key to reboot the balance and save the setting

The current testing method type is shown on the screen, for instance, Program: 03

10.7 Printout

Press PRINT key to print the test results to a dedicated printer or to other peripherals such as a computer. The factory default baud rate is 9600 and no parity.

11 First commissioning

After the first successful operation of the new Halogen Moisture Analyzer, you can perform the first commissioning immediately. Through the first commissioning you will become familiar with the instrument.

In the first commissioning, the equipped sample (glass fiber filter paper) was used to measure the moisture content and the instrument operates according to the factory settings.

- Power on: connect the moisture analyzer to the power supply, the instrument shows

the model no. and 0.000g sequentially.

- ▶ Open the heating chamber and press TARE key to zero the balance.
- ▶ Start measuring
- ▶ Place the sample on the sample plate.
- ▶ Close the heating chamber.
- ▶ Press START key and the instrument begins the drying process according to the above default settings.

Drying process

You can trace the measurement process on the display

- The drying process continues to be displayed as a coordinate graphs.
- The current temperature of the heating unit, the past drying time and the current mass or moisture content are displayed (press “%/g” key to switch between mass and % content freely)
- Selected settings are displayed.
- Press STOP key to terminate the drying process at any time.
- After the drying process is over, the moisture content of the sample is displayed on the screen (press “%/g” key to switch between mass and % content freely)
- Press TARE key to return back to normal weighing mode.

Removing samples

Watch out for risk of burns: samples, measuring tray and measuring tray bracket are still very hot.

After the drying process is over, open the heating chamber and gently remove the measuring tray with the measuring tray bracket.

12 Measurement

The testing procedures of the moisture analyzer is listed as below:

- A. Turn on the balance. The moisture analyzer needs to be preheated for more than 30 minutes.

- B. Calibration (see Chapter 8).
 - C. Set up heating method(see Chapter 7 and select between C6--0, C6---1 and C6---2).
 - D. Set up heating temperature (see Chapter 10.1).
 - E. Set up shutdown mode (see Chapter 10.3 and 10.4 for heating time and weight loss rate).
 - F. Prepare the samples to be tested
 - 1) Place an empty measuring tray on the measuring tray bracket
 - 2) Press TARE key to zero the weight of the measuring tray.
 - G. Remove the measuring tray and place samples ($\geq 0.5\text{g}$) evenly on the measuring tray.
 - H. Place the measuring tray with samples back on the tray bracket and the screen displays the weight of the sample.
 - I. Close the heating chamber.
 - J. Press START key to start measurement.
 - K. The display shows the current weighing value, press the “%/g” key to convert the current measurement result.
 - L. The display shows the final moisture content of the sample when the measurement is over. Press TARE key to return to normal weighing mode.
 - M. Press PRINT key to print the current weighing result to a printer or other peripherals.
- Attention: you can press STOP key to terminate this measurement at any time.

13 Test optimization

13.1 How to get optimal testing results

In order to obtain optimal testing results, parameters and instrument settings that can influence the measurement process should be optimized.

13.2 Measuring principle of Halogen Moisture Analyzer

On the basis of weightlessness principle, this instrument measures moisture content by weight loss of heat dried samples. In principle, the halogen moisture analyzer consists of two devices: an analytical weighing unit and a heating unit. In contrast to other methods of weight loss, the halogen moisture analyzer uses halogen heating technology to ensure quick

heating and rapid weighing results.

No matter which measurement method is used, correct sample preparation and correct



selection of measurement parameters can improve measurement results and quality.

- Sample size
- Drying temperature
- Shutdown mode
- Drying time

Incorrect parameter settings may lead to inaccurate testing results. Therefore, it should be checked whether the measurement results of various samples meet the expected results.

13.3 Heating temperature

- The heating temperature plays a critical role in controlling the heating time. Too low temperatures can lead to long drying time.
- Selecting a suitable temperature requires neither decomposing nor changing the chemical structure of the sample, typically set to 105 degrees unless the sample or industry has special requirements
- Some samples will have different moisture contents measured at different heating temperatures. In this case, try to increase the heating temperature to compensate for the deviation

13.4 Heating time

- Automatic shut-off mode A3 is recommended when there is no suitable heating time, and heating process stops automatically when the moisture loss exceeds 1 mg/60s.
- Timed heating: after heating for a preset time, the heating process stops automatically to terminate this measurement.

13.5 Sample weight

The sample weight can influence both measuring time and accuracy. The maximum sample weight should not exceed 50g. The more weight the sample has, the more water will evaporate and the longer the test time becomes. If the weight of the sample is too small, it will affect the repeatability and accuracy of the measurement. In general, a 20-gram sample can obtain consistent results, but it takes longer testing time.

The relationship between sample weight and repeatability is shown in the figure below

Sample weight	Repeatability
0.5g	1.0%
1g	±0.5%
3g	±0.2%
5g	±0.1%
10g	±0.05%

13.6 Sample preparation

The test samples should be typical in order to obtain accurate and reproducible results. While preparing the samples, make sure that the sample is evenly distributed on the measuring tray to avoid accumulation and excessive amounts.

Sample processing: When necessary, the sample should be ground to increase the surface area. To ensure a better, faster release of water when heated, do not heat the sample while it is grinding.

Tips: You can use fiberglass disks to increase the heated area of the liquid and shorten the heating time.

13.7 Sample type

1) Pasty, fat-meltable substances

Use fiberglass disks to increase the surface area of the sample, such as butter. The moisture content of these substances can be more evenly distributed through fiberglass disks to increase the surface area of the sample, ensuring a faster and complete evaporation.

2) Liquid substances

The liquid forms water droplets on the sample tray to prevent rapid drying. In this case, the glass fiber filter paper can be used to evenly distribute the liquid over a large surface area to reduce drying time.

3) Easy crusting, temperature-sensitive substances

Samples that form a shell on the surface completely obstruct the moisture measurement. At this time, the sample can be covered with glass fiber filter paper and gently heated at a suitable temperature or via step heating, which can improve the repeatability of the measurement.

4) Sugar-containing substances

Substances containing large amounts of sugar are easily scorched. Make sure the sample is evenly distributed into a thin layer and choose the right temperature. You can also cover the sample with glass fiber filter paper to improve its repeatability.

Warning:

The following substances may cause fire, explosion, damage or injury. For substances with potential safety hazards, please carefully analyze the possible dangerous consequences. In this case, the instrument should be guarded by dedicated personnel and wear appropriate protective devices.

1) Volatile substances

For volatile substances, fast heating is recommended so that the loss of moisture can be limited before the sample volatilizes. The test should be conducted in a safe, dry, low-temperature environment to prevent explosion or fire. Use 1g or less of the sample for testing.

2) Toxic substances

Toxic or corrosive substances should be dried in a ventilated display window.

3) Corrosive substances

Substances that produce corrosive gases, such as acidic substances, should be tested with as little sample as possible. Because the corrosive gases it generates can condense on analytical

instruments and cause corrosion.



14 Maintenance

14.1 Cleaning

1 Disconnect the power supply before cleaning Moisture Analyzer

2 Ensure no solution come inside the Moisture Analyzer.

3 Ensure Moisture Analyzer cools down before cleaning

- ▶ Clean the moisture analyzer regularly
- ▶ The cover surface and temperature sensor can be scrubbed with a lint-free cloth

slightly dampened with water or a neutral detergent.

- ▶ Glass surface can be cleaned with glass clean agents.
- ▶ Do not use solvents, irritating chemicals such as ammonia, abrasive solvents

14.2 Trouble-shooting

Fault	Cause	Solution
Can not power on	<ul style="list-style-type: none"> •Power supply is not connected •Fuse damaged 	<ul style="list-style-type: none"> •Check power supply connection and voltage •Replace fuse
Display "HHHHHH"	<ul style="list-style-type: none"> •Overload—the weight of sample exceeds max weighing capacity 	<ul style="list-style-type: none"> • Reduce sample weight
Display "LLLLLL"	<ul style="list-style-type: none"> •Under load---sample tray bracket missing 	<ul style="list-style-type: none"> •Insert sample tray bracket
Unstable weighing value	<ul style="list-style-type: none"> •Bad weighing environment •Preheating time is not enough • Interference by housing, bracket handle and other external devices •Samples are volatile substances 	<ul style="list-style-type: none"> •Ensure environmental condition and best position •Preheat 30 minutes before measurement •Ensure no interference between sample tray, sample tray bracket, housing and handle, etc •Ensure sample tray bracket is installed correctly and intact •Due to constant loss of sample weight, volatile substances in the sample will also prevent the stability of weighing results.
NO CAL	<ul style="list-style-type: none"> •Location of standard weight is incorrect •No tare before calibration •Unstable weighing value 	<ul style="list-style-type: none"> •Tare the balance before calibration •Calibration weight should be our F1 class 100g standard weight •Ensure displayed value is stable before calibration
No heating after power on	<ul style="list-style-type: none"> •Halogen lamp damaged or the heating threshold switch 	<ul style="list-style-type: none"> •Contact local dealer

	damaged	
The measurement result has a low repetition rate	<ul style="list-style-type: none"> •Instrument is located in an unstable position and the level feet is not properly adjusted •Surrounding environment is not stable (vibration, air, moisture) <ul style="list-style-type: none"> •Samples are not sufficiently dried •Samples are not distributed evenly on the sample tray •The initial weight of the sample does not remain the same •The drying time is too short under the selected timed shutdown condition, extend the drying time or change to an appropriate automatic shutdown mode •Samples are not sufficiently dried (eg, materials that are prone to conjunctiva). Samples should be dried with glass fiber filter paper. •The selected temperature is too high, the sample is oxidized or decomposed, lowering the drying temperature <ul style="list-style-type: none"> •Sample particles are uneven or too large •The boiled or spilled droplets change the weight of sample. Lower the drying temperature. •If the problem still cannot be solved, contact your local dealer 	

15 RS232C Interface

For the connection of a peripheral device (printer, computer) the balance is as per series equipped with a RS232C-interface.

The following conditions must be met to provide successful communication between the weighing balance and the peripheral devices.

- Connect balance using a suitable cable with the interface of the peripheral device.
- Communication parameters (baud rate, bits and parity) of balance and peripheral device must match.

This data exchange is asynchronous using ASCII - Code.

15.1 Technical data

Connection

9 pin d-subminiature bushing

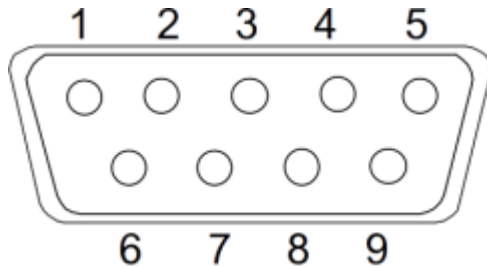

Pin 2: Receive data
Pin 3: Transmit data
Pin 5: Signal ground

PIN FUNCTION

PIN 2-----TXD sending

PIN 3-----RXD receiving

PIN 5-----GRD signal ground

Data communication settings (factory default setting)

Baud rate: 9600

Data bits: 7

Stop bit: 1

Parity: No

15.2 Interface

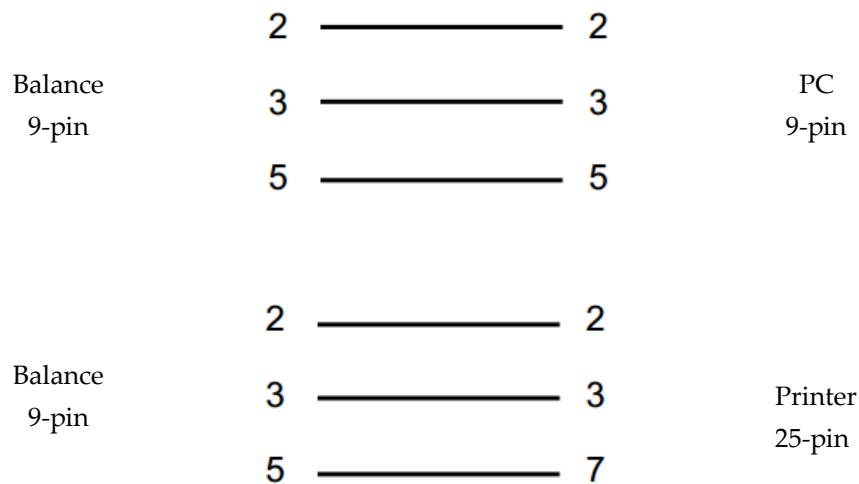

15.3 Printing mode

Drying temperature: 105°C

Drying time : 5 min

Drying Mode : STD

Stop Mode : Time

Initial weight 10.000g

Final weight 5.000g

Final result 50.00%MC



Gram Precision S.L.

Travesía Industrial, 11 · 08907 Hospitalet de Llobregat · Barcelona (Spain)

Tel. +34 902 208 000 · +34 93 300 33 32

Fax +34 93 300 66 98

comercial@gram.es

www.gram-group.com